

Our Mission Statement

United Methodist Church is a Christ-centered fellowship called to offer the best we can possibly give to God, as we care for our community and world through...

- ...worshipping, glorifying, and honoring God, the Father, Son, and Holy Spirit.
- ...inviting all to grow in the knowledge of the Lord.
- ...living a Spirit-filled life through our actions and words.
- ...offering the love of Christ to everyone.

- G – Growth through making disciples of Jesus
- R – Reaching our community and world
- A – A family where all people can belong
- C – Christ-centered worship and learning
- E – Excellence for God's glory

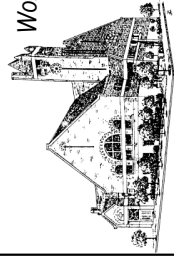

Worship & Education Center - 219 W. Mulberry
Offices - 212 W. Walnut
Kokomo, IN 46901

Sunday Worship: 8:15 am & 9:25 am

Phone: (765) 457-5329

Web page: www.kokomograce.org

The Congregation of Grace United Methodist Church

Pastors

Stephen A. Beutler Chris Roberts
Larry Newberg, Visitation Pastor

Our Missionaries

Jeff Newton, Kokomo Urban Outreach Ministries
Dr. Robert Marke, Medical Missionary, Kissy, Sierra Leone
Rev. Ken Vance., Missionary, Ndola, Town Center, Kafakumba
Pastor's School, Africa

Specialized Ministries

TJ Knowland, Youth Director
Randy Manning, Director of Music
Barbara Hobbs, Pianist/Organist
Jacque Hunt, Ensemble Director
Debbra Long, Volunteer Parish Nurse
Phill Montgomery, Counselor
Cindy Lovegrove, Office Manager
Carisa Durham, Childcare Provider

For it is by grace you have been saved through faith - and this not from yourselves, it is the gift of God - not by works, so that no one can boast. For we are God's workmanship, created in Jesus Christ to do good works, which God prepared in advance for us to do."

Ephesians 2:8-10

Grace Notes

JANUARY 2008



Lessons from a Cup of Coffee

A group of alumni, all highly established in their respective careers, got together for a visit with their old university professor. The conversation soon turned to complaints about the endless stress of work and life in general. Offering his guests coffee, the professor went into the kitchen and soon returned with a large pot of coffee and an eclectic assortment of cups: porcelain, plastic, glass, crystal - some plain, some expensive, some quite exquisite. Quietly he told them to help themselves to some fresh coffee.

When each of his former students had a cup of coffee in hand, the old professor quietly cleared his throat and began to patiently address the small gathering. "You may have noticed that all of the nicer looking cups were taken up first, leaving behind the plainer and cheaper ones. While it is only natural for you to want only the best for yourselves, that is actually the source of much of your stress-related problems."

He continued. "Be assured that the cup itself adds no quality to the coffee. In fact, the cup merely disguises or dresses up what we drink. What each of you really wanted was coffee, not a cup, but you instinctively went for the best cups...then you began eyeing each other's cups...."

"Now consider this: Life is coffee. Jobs, money, and position in society are merely cups. They are just tools to shape and contain Life, and the type of cup we have does not truly define nor change the quality of the Life we live. Often, by concentrating only on the cup, we fail to enjoy the coffee that God has provided us. God brews the coffee, but he does not supply the cups. Enjoy your coffee!"

The happiest people don't have the best of everything, they just make the best of everything. So: Live simply. Love generously. Care Deeply. Speak kindly. Leave the Rest to God. Sounds a lot like the counsel we received from John Wesley. Better yet, it really sounds biblical.



DR. BEN WITHERINGTON III TO SPEAK AT GRACE

Ben Witherington III, noted Bible scholar and professor of New Testament Interpretation at Asbury Theological Seminary will speak and preach at Grace on Sun., February 24. Witherington holds degrees from UNC Chapel Hill, Gordon-Conwell Theological Seminary and the University of Durham in England. He is considered one of the top evangelical scholars in the world. He is an elected member of the prestigious SNTS, a society dedicated to New Testament studies.

A popular lecturer, Witherington has presented seminars for churches, colleges and

Continued on page 4



United Methodist Church
212 West Walnut Street
Kokomo, Indiana 46901
www.kokomograce.org



NONPROFIT ORG.
USPOSTAGE PAID
KOKOMO, IN
PERMIT NO. 91

TAKE A LOOK AT OUR 2007 GOALS HOW DO YOU THINK WE DID?

G – Growth through discipleship

- Our goals were:
 - Membership growth at 5%
 - Attendance growth at 5%
 - Bible Study growth at 5%
 - At least 200 people regularly committed to Bible Study/Small Groups

R – Reaching others for Christ

- Our goals were:
 - Share the love of Jesus Christ with others
 - Increase our Mission giving to 5%
 - Increasing our mission participation
 - Increasing local mission time and money

A – A Family we belong to

- Our goals were:
 - Be a welcoming family where Christ is celebrated
 - Promote a friendly welcome with all who attend

C – Christ Centered Worship

- Our goals were:
 - Continue to revitalize our community of faith through vibrant celebrations of worship
 - Enable and encourage increased participation by laity in worship

E – Excellence

- Our goals were:
 - Remodel Fellowship Hall, lower level and restrooms
 - Improve public relations with better communications and publicity
 - Be more like Christ as we strive for unity in our church
 - Give our best for the glory of God in everything we do

Order 2008 Altar Flowers

In Honor of a Memory of a Loved One



You may sign up for altar flowers for 2008 in Fellowship Hall after Sunday services or contact Angela Stamper at 457-6716. The cost is \$35.00.

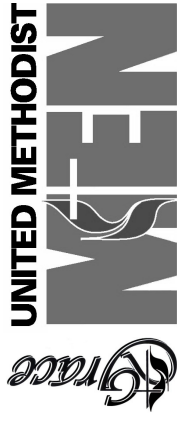

MEN'S GROUP TO VISIT KENTUCKY WITH HENDERSON WORK CAMP TEAM

Tim Garner, team member and documentary photographer, will display highlight images he has captured from last September's Work Camp at Henderson Settlement, at their January 28 meeting. His slide show will help you participate with them and will enable team members to describe their activities.

Women are always welcome to attend Grace's UM Men's meetings. Reservations are needed only for the meal. Reservations for the 6:00 p.m. catered meal may be given to Val Harris at 453-6952.

CD's or tapes are available for each Sunday Worship Service. Contact the church office for more information.

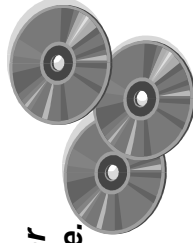

ADDED GRACE MEETING

Added Grace for January. Added Grace will meet in Fellowship Hall on Tuesday, January 8, 2008 for our first meeting of the year. Hazel will cook for us and the meal cost will be \$5. We won't have a formal program but will discuss the meeting plans and trip plans for 2008. Please come and meet with us and find our what 2008 has in store.

Added Grace Meeting for February. For the February meeting of Added Grace we will have "Lunch with Mayor Greg Goodnight". Please plan to attend and hear Greg's ideas, and ask our new mayor your questions. The lunch meeting will be on Tuesday, February 5, 2008 @ 11:30 AM in Fellowship Hall. The price of the meal will be \$5.00 and Hazel Hodge will be preparing our food. Reservations can be made with Peggy Hobbs at 452-4394.

"May the God who gives endurance and encouragement give you a spirit of unity among yourselves as you follow Christ Jesus, so that with one heart and mouth you may glorify the God and Father of our Lord Jesus Christ. Accept one another, then, just as Christ accepted you, in order to bring praise to God."
Romans 15:5-7

Dear Grace Members:

I first hope that you are having a blessed day. You have been such a blessing to me and I am very grateful for everything you have done for me. You have impacted and helped shape who I am today. I am currently a sophomore at Indiana Wesleyan University studying Youth Ministry. God has definitely moved in me while being here and continues to bless me.

The reason for this letter is to let you know of an opportunity that has come up for me. I recently applied and was accepted to go on a short-term mission trip with a team to Togo, West Africa. I have felt God's presence and call on my heart and life to be his hands and feet in serving those in Togo. We will be leaving May 2nd and return May 16th. I definitely want to let you know that this is completely a team effort. If we did not have the others on the team we would crumble completely. We will be doing mission work in the capital city of Lome for the first week and then travel north. We will be doing construction and also children's and youth work in building relationships with them.

Your support will be helpful in so many ways. Your prayers for our team will help us stay strong together, individually, but most importantly in God. We ask that you pray for us through the entire process. We will be growing as a team before we leave and your prayers will be a huge asset. We ask that you pray for strength and endurance while we are there and we feel like we can go no further. In those times your prayers will help so much.

We also need support financially to be able to be there to do the ministry. Each individual on our team is responsible for raising \$3,000. We as team members are giving ourselves because it would be unfair to ask others to give if we have not given first. You can write a check to Indiana Wesleyan University with "World Impact" on the memo line. Please do not put my name anywhere on the check because then you will not be able to receive tax credit. If you are willing and able to help support us in any way it is greatly appreciated.

God has truly blessed me with you in my life. I pray that this would be a great week for you!

In His Everlasting Love,
TJ Knowland

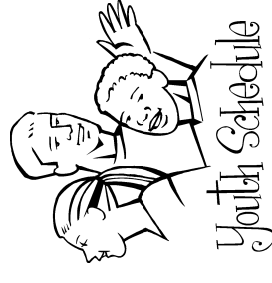

Snow is falling. Cars are getting stuck. And you are waiting to find out when the next youth event is. Well here is what is going on in January. See you there!

Sun., January 6
Sun., January 13

Jr./Sr. High UMYF @ 6pm
Sr. High Spud Lunch
Fundraiser for Ski trip -
Right after Sunday School
Jr./Sr. High UMYF @ 6pm

Fri., January 18-20
Sun., January 20
Sun., January 27

Jr./Sr. High Ski Trip
Sr. High UMYF
Jr. High UMYF
Jr./Sr. High UMYF @ 6pm

Thanks for a Great Year!
Wow! What a year 2007 was! I first want to thank everyone who helped out in any way this past year. The experiences we shared were absolutely priceless and amazing. There were definitely some great memories made that's for sure! Every single one of my expectations were exceeded and met, and my prayer is that 2008 will be just as great.

This next year will be just as amazing! Some events to look for will be the Sr. High Ski Trip, Jr. High Ice Skating, Kokomo District Lock-in, Flamingo Flocking, Indiana Wesleyan University Youth Rally and many more.

Once again I want to thank everyone from the bottom of my heart. You have made this past year such a success. Without your prayers and support nothing would have been possible!

In His Amazing Love,
TJ Knowland

We promise to uphold our church by our presence

Nov 25
213

Dec 2
277

Dec 9
206

Dear Grace UMC Family,

Now that my degree has been completed and my certificate received (just moments ago via the USPS), I want to take this opportunity to thank you for the scholarship I was granted in August. I have been working on my Master of Arts in Marriage and Family Counseling for three and a half years now. It has required a lot of hard work and sacrifice for me, but maybe even more so for Chris and the kids. The \$950 that I was awarded through Grace UMC went a long way toward supporting us in this final semester. When God called me to pursue this degree in 2004, I had no idea how God would carry it through to completion; but, I stepped out in faith and trusted that He would provide. I have been utterly amazed as I have watched His hand at work. God has supplied people to love and care for our children, people to pray for us and bring us meals, and financial support for a variety of expenses that have come up along the way. God is so good.

It is my hope that I will be able to become more involved in the congregational ministries of Grace UMC now that I am finished with this educational commitment. I also pray that I will be able to serve Grace with all that I have learned and the gifts that God has bestowed upon me. I appreciate your continued prayer and support as we all journey in ministry and service together.

Grace and Peace,
W. Renee Roberts, MA

*Pastor, Members and Friends at
Grace:*

Thanks so much for your contribution (G. Edward Alley Scholarship in Pastoral Counseling at Garrett Evangelical Theological Seminary). Also, thanks to Greg and Jan Wall for attending the event on November 11 and for the honor you gave me in your newsletter. Grace Church holds a special place in my heart.

Ed Alley



Join Pastor Chris online at

www.pastorchrisroberts.blogspot.com

"To be changed" is a place to read his thoughts, wonderings, and other fun items.

January Anniversaries



5th	Richard & Bonnie Fretz	35 yrs
18th	Bob & Pam Lyon	39 yrs
23rd	Christopher & Elizabeth Riesen	26 yrs
24th	Arthur & Ann Hollingsworth	61 yrs
29th	Larry & Barbara Moss	42 yrs

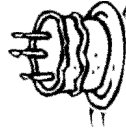

January Birthdays

1-George Hoshaw	15-Bill Bagwell
Dian McKinney	Joe Wesche
2-Melanie Spalding	Courtney Mitts
3-Paul Eichholz	16-Hazel Hodge
4-Jean Conner	Pam Prather
Katherine Wood	Brian Van Horn
5-Jeff Foust	17-Milt Brown
Linda White	Robert Lutz
6-Marleta Newberg	Doug Borders
7-Ron Burkhalter	18-Leanna Zimmerman
8-Ned Reyburn	19-Matt Wesche
Marilynda Bennett	20-Robert Roler
Dee Ann Colescott	21-Harlo Westlin
Melissa Zimmerman	24-Pat DiSalvo
10-Jo Alexander	26-Margaret Seymour
Marian Victor	Kurt Kingseed
Shirley Hoy	28-Stanley Markus
Patrick Borders	29-Kyle Hughes
11-John Snead	Kyle Hartzog
14-Linda Maus	30-Katherine Thomas
Cheri Lovelace	Glen Harland
	Karen Williamson

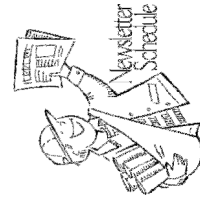

FEBRUARY
Grace Notes Deadline
Material for the
FEBRUARY newsletter needs
to be in the church office by
JANUARY 15!



2008 United Methodist Women Executive Board

President: Nancy Hefley
Vice President: Norma Raber
Secretary: Adair Younce
Treasurer: Donna Brownfield
Asst. Treasurer: Debbie Mitts
Nominations: Open
Membership: Joy Loop
Prog. Resources: Ele King
Reading Program: Dianne Waggaman
Communications: Jan Wall

Mission Coordinators

Spiritual Growth: Phyllis Jean Smith
Education & Interpretation: Betty Corn
Membership, Nurture & Outreach: Ann Winger
Social Action: Lois Hunkler

Committees

Bereavement Dinners: Betty Hegenbart
Barbara Angel
Church Women United: Betty Corn
Wedding Committee: Lois Hunkler
Jackie Plank
Sue Flasche
Dianne Waggaman



Upcoming Events:

Remember this guy?
Sloppy Joe

He's here to remind you that Grace United Methodist Women will be serving Sloppy Joe sandwiches and bowls of homemade soup at the Samaritan Caregivers Chocolate Celebration on Thursday, February 7th at the Kokomo Mall. Don't forget to top your meal off with lots of chocolate! All Grace UMW proceeds go to local missions, including Samaritan Caregivers.

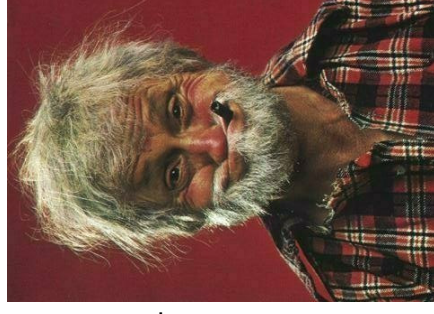

JANUARY PREACHING SCHEDULE

Jan 2 Pastor Steve Beutler
Jan 13 Pastor Mike Dominick
Jan 20 Pastor Paul Rogers
Jan 27 Pastor Steve Beutler

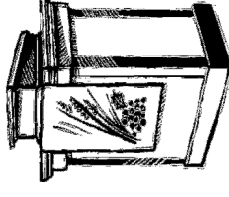

YELLOW BAG COLLECTION STARTING IN FEBRUARY

The Mission Ministry Team will soon be starting a new way to collect items needed for CAM, Nesting Doves, Kokomo Urban Outreach and Open Arms. Yellow bags will be available at the Church Parlor beginning in February. We are hoping that the yellow bags will make it more convenient to shop and also help you bring your donated items back to the church. The items requested by each organization will be listed on the bag, so it will guide you as to what donations are needed.

At the end of each month, mission team members will gather all that has been donated and deliver those items to their appropriate places. Donations will be collected at the table in the Parlor beside the entrance to the sanctuary. If you need assistance, please ask an Usher or Sunday morning Greeter to help you.

"Think Yellow" when you shop for missions at Grace United Methodist Church as you use the Yellow bags for Missions.

THE NEW YEAR BRINGS A NEW ADDITION TO THE LIBRARY

Throughout the year, new books are added to the Grace Church Library, but we are happy to announce a new shelf with "Pastor Recommended Books." Pastor Chris has ordered several new books for this shelf and included a personal recommendation in each. He has taken the time to give insights for each book, that I think you will find quite helpful.

The new book titles include:

- Stop Dating the Church by Joshua Harris
- Blue Like Jazz by Donald Miller
- Simply Christian by N. T. Wright
- United Methodist Beliefs by William H. Willimon
- Carpe Diem-Seize the Day by Tony Campolo
- They Like Jesus But Not the Church by Dan Kimball
- The Politics of Jesus by John Howard Yoder
- The Church and Abortion by a collection of authors
- A New Kind of Christian by Brian McLaren
- Shaped by the Bible by William H. Willimon
- Resident Aliens by Hauerwas and Willimon
- Unbinding the Gospel-Real Life Evangelism by Martha G. Reese

The winter months have arrived, so snuggle up to the fire and enjoy a good book. You might just learn more about your faith, the Methodist beliefs or how to live your Christian life day-to-day. Pastor Chris has included these books and comments on his blog, so check it out.

In case you can't find the Grace Church Library, it is located in the parlor, by the elevator. Some people learn by listening, some people learn best by reading and some people just like to get lost in a good book. For myself, I simply love books, so check out one of the "Pastor Recommended Books" and enjoy reading one of the new additions to our library!

Susan Garner
Grace Church Librarian

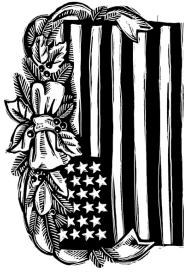
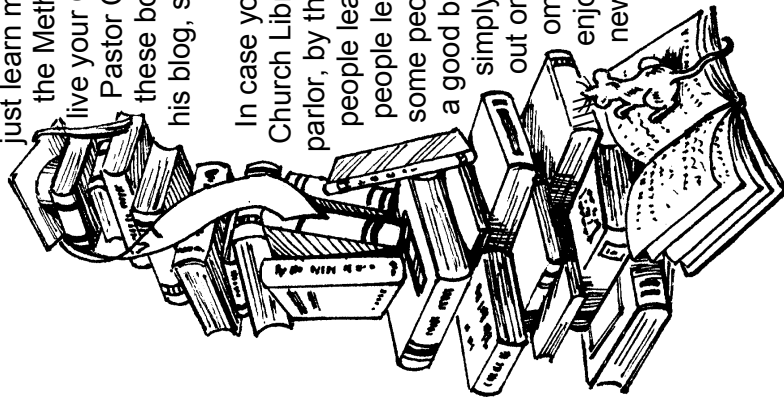

Remembering Those
in the Military

TREATS FOR TROOPS

Each week, our bulletin lists servicemen with a personal connection to Grace Church. Christmas Boxes were sent to each of these servicemen. The boxes included a variety of snack items, a devotional book, and a letter from Pastor Steve. We want to thank the following people for funding this project:

Beverly Snodgrass
Kirby and Jo Alexander
Lloyd and Dorothy Johnson
Rich and Ann Bradshaw
Ron and Jan King
Ned and Ellen Reyburn
Larry and Norma Raber
John and Mary Lou Snead

Let us be thankful for all of our dedicated troops and pray for their safe return.

SPECIAL THANK YOU

Thank you for the package of treats, books and the kind letter. Most of all thank you for your support. I am truly amazed at the outpouring of love and prayer that have been prayed for myself and all the men and women here with me. May God Bless your Church and you and your family! I wish you all a very Merry Christmas and a Happy New Year!

Thank you so very much!
MSgt Harold M. Edwards Jr.

P. S. Please continue to Pray for us

Continued from page 1

biblical meetings in the United States and internationally. Witherington is the Author of over 30 books, including The Jesus Quest, and The Paul Quest. Witherington is seen regularly on The History Channel, NBC, ABC, CBS and CNN and been interviewed by many radio networks across the country. Don't miss this exciting event in the life of our congregation, brought to us through the Cultural Events Ministries.

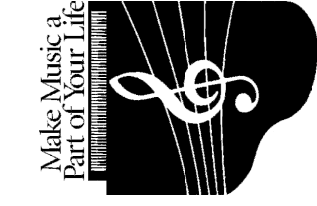

GRACE UMC MUSIC

ALTAR CHOIR

We would like to thank the members of the Altar Choir for their hard work during Advent and Christmas. They are now working on Part II of the cantata entitled "Emmanuel Has Come" which will be sung on Palm Sunday March 16th, 2008.

BASIC & ADVANCED MORRISON YOUTH HANDBELL CHOIRS

The basic and advanced youth handbell choirs both played during services on or before Christmas Eve. We want to thank Julie Maupin for volunteering her time to rehearse with and direct the basic group. Both groups will begin rehearsals again on Sunday evenings from 5:00-6:00 starting January 6th.

INSTRUMENTAL ENSEMBLES

The **Grace Chamber Ensemble** has been in existence for 12 years and is open to any adult or youth who plays a band or orchestra instrument at high school level or above. The group plays for the 9:25 Worship service about once a month and practices one or two times a month on Sunday evenings from 8:00-9:00. The Chamber Ensemble occasionally performs for the community and other church events. New members are always welcome.



GUMBY (Grace United Methodist Band-Youth) is a new instrumental group formed at the request of some sixth graders. It is open to any youth who has played a band or orchestra instrument for at least 1 year. The group will be scheduled to play during the 9:25 Worship service several times a year. Starting in January 2008, rehearsals will be **Sunday afternoons from 4:15-5:00**. New members are always welcome.

To join either group, please contact
Jacque Hunt 459-5241
jacquekok@insightbb.com.

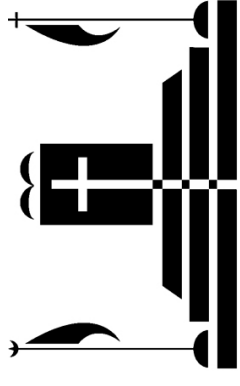

PULPIT EXCHANGE IN JANUARY

Following the wonderful response to last year's pulpit exchange with St. Luke's UMC and Main Street UMC, we have decided to host a pulpit exchange once again this year. Mark your calendar and come expecting a real blessing as we all look forward to hearing from the Senior Pastors of our sister churches in Kokomo.

- On January 13, Rev. Mike Dominick from St. Luke's UMC will be our guest preacher during the 9:25 a.m. worship service.
- On January 20, Rev. Paul Rogers from Main Street UMC will be our guest preacher during the 9:25 a.m. worship service.

Pastor Steve will preach at St. Luke's UMC and then Main Street UMC during those two Sundays.

LEADERSHIP RETREAT At

Grace UMC

**January 12, 2008
9:00 a.m. - 2:00 p.m.**

**With Dr. Doug Anderson,
Church Growth Consultant**

**Leading our discussion as we
set our direction for the
next five years.**